

Practical 1P3

Young's Modulus and Stress Analysis

What you should learn from this practical

Science

This practical ties in with the lecture course on Elastic Deformation of Materials. It will help you understand:

1. Hooke's law of elasticity;
2. how to relate strain states to different orientations;
3. relations between elastic moduli E , G and ν .

Practical skills

You will learn how to use strain gauges to determine elastic properties of a material. You will learn how to use spreadsheets to process data and present your results graphically.

Data analysis and experimental methods

The practical ties in with the lectures on Introduction to Errors and Measurement. You will learn how to assess, minimise, and report errors in experimental data.

Assessment

For this practical your lab book will be assessed and the mark will contribute towards Prelims. You are also required to write a report of this practical which will be assessed formatively – feedback will be given but the assessment of the report will not contribute to Prelims. General guidance for the keeping of lab books and the writing of reports is provided separately.

Safety considerations

No unusual safety problems with this practical.

Rough timetable

Day 1:

Introduction to practical by SD.
Experimental work and data analysis

Day 2:

Finish off experiments and data analysis, if needed.

Overview

The objectives of this practical are

1. to demonstrate Hooke's law;
2. to determine the Young's modulus and Poisson's ratio of a material;
3. to determine the shear modulus of the material;
4. to check the inter-relation of E , G and ν .
5. to make reasoned estimates of experimental errors.
6. to think about how to minimise errors in performing measurements.

The practical involves applying loads to a beam and measuring the resultant strains as a means to establish the Young's modulus, Poisson ratio, and Shear modulus of the material from which the beam is made. The device used to measure strain is the electrical resistance strain gauge. This is the most widely used device for measuring elastic strains. It is essentially a strip of metal foil which is well glued to the surface where the strain is to be measured, so that when the material is strained, the strain at the surface is fully transmitted to the metal foil. Normal strain along the length of the strip causes a small change in resistance of the gauge, largely because of the change in length and cross-sectional area of the strip, although there is also a slight change in its resistivity. Because small changes in resistance are easy to measure accurately, the gauge gives an accurate reading of the normal strain along the direction of the strip in the gauge. The change in resistance, and hence voltage across the strain gauge for a constant current, is proportional to the strain; the gauge manufacturer supplies the value of the constant of proportionality. For the strain gauges and current used here the conversion constant provided is $\varepsilon = 3.803 \times 10^{-7} V$, where $\varepsilon = \text{strain}$ and $V = \text{voltage across strain gauge (measured in microvolts)}$.

Experimental details

The experimental work in this practical is very simple but proper working out of the results and consideration of errors will take some time. Where possible, errors should be considered before and during the measurements in order to optimise the outcome of the measurements and provide a reliable assessment of their accuracy.

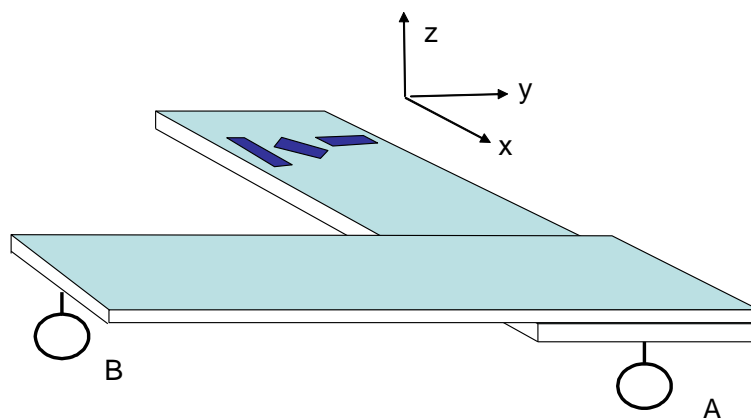

Figure 1: The cantilever beam used for bending and torsion experiments.

Part 1: Bending

This part of the practical involves the simple cantilever bending of the beam to which the strain gauges are attached, achieved by suspending the load pan from point "A" shown in Figure 1.

Apply a range of different loads using the weights provided, recording the six strain gauge outputs for each load, corresponding to the gauges pointing in the x, y and 'angled' directions and mounted to the top and bottom surfaces of the beam. Plot suitable graphs of the gauge readings as a function of the applied load (use a spreadsheet or graph paper and stick graphs into your lab book). The linearity of the graphs will demonstrate the validity of Hooke's law.

Convert the strain gauge readings to strains ε_x and ε_y , and the loads to Newtons. Measure the dimensions of the beam, then use the stress/strain data to calculate the Young's modulus E and Poisson's ratio ν of the beam (Use the gradients of the stress/strain lines, rather than individual readings - the LINST function in Excel is useful here.) The theory for this part of the practical is given in Appendix 1.

Estimate the likely errors in each measured (or stated) quantity, and combine them appropriately to give an overall error in your measurement of Young's Modulus. What are the main sources of error and why? What type of error are they (random or systematic)? How has your experimental method (such as the number and sequence of measurements, care taken to ensure accurate readings) contributed to the error? Are there obvious steps you can take to reduce errors, such as recording more data points or testing calibration errors of the measurements instruments?

Based on the value for E and the estimated accuracy of your measurement, what material do you think the beam is made of?

From the ε_x , ε_y and ε_θ readings, work out the angle at which the central angled gauge is fixed, together with an estimate of the accuracy of your value. The theory for this part of the practical is given in Appendix 2.

Part 2: Torsion

This part of the practical involves torsion (twisting) of the beam to which the strain gauges are attached. It is achieved by supporting loading eye "A" shown in Figure 1 using the scissor-jack table to prevent deflection, and applying a load to loading eye "B".

Repeat the process you carried out for the bending experiments, applying a range of loads to the beam, and recording each of the strain gauge outputs. Describe the qualitative behaviour observed. Can you explain it?

Convert the strain gauge outputs to shear strain (theory in Appendix 2) and the torsional loads to shear stress (theory in Appendix 3). Plot the measured stress/strain relationships and obtain a value of the shear modulus $G =$

$\sigma_{xy}/2\varepsilon_{xy}$. As before, establish the accuracy of your value and comment on the principal sources of error.

For isotropic elastic materials,

$$G = \frac{E}{2(1 + \nu)}$$

Based on your estimates of the errors, check the consistency of the value for G you measured by torsional loading with that obtained using the measured values for E and ν . If they are inconsistent, why do you think this is? Suggest ways in which the inconsistency might be addressed.

Conclude your write-up with a summary of the values measured, the accuracy with which they can be measured using this apparatus and the most important considerations when performing the measurements to achieve best results.

Appendices: Elasticity theory

1. Cantilever beam theory

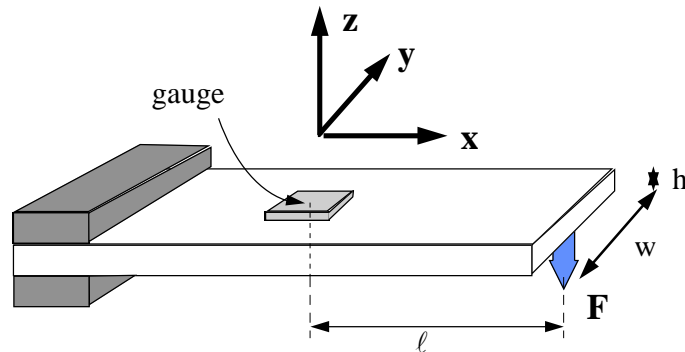

Due to the applied force F , a couple of moment $F\ell$ (the bending moment) acts on the beam cross section at the gauge position.

The bending stress σ_x varies linearly from a maximum σ_{\max} at the top surface to a minimum $-\sigma_{\max}$ (compressive) at the bottom surface. Hence at a height z from the centre line of the beam, the stress σ_x is:

$$\sigma_x = \frac{\sigma_{\max} z}{(h/2)}$$

This stress acts on an area $= w \cdot dz$ at a distance from the centre line (moment arm) $= z$. The total moments from all of these stresses internal to the beam must balance the moment $F\ell$ applied externally.

$$\begin{aligned} F\ell &= \int \text{force} \times \text{moment arm} \\ &= \int \text{stress} \times \text{area} \times \text{moment arm} \\ &= \int_{-h/2}^{h/2} \frac{\sigma_{\max} z}{(h/2)} w \cdot dz \cdot z \\ F\ell &= \frac{2w\sigma_{\max}}{h} \int_{-h/2}^{h/2} z^2 dz \\ \sigma_{\max} &= \frac{6F\ell}{wh^2} \end{aligned}$$

The tensile strain ε_x at the gauge position is then

$$\varepsilon_x = \sigma_{\max} / E = \frac{6F\ell}{Ewh^2}$$

The strain ε_y is given by:

$$\varepsilon_y = -\nu\varepsilon_x$$

where E is Young's modulus and ν is Poisson's ratio.

2. Strain at the central angled gauge

Stress and strain are not scalar or vector quantities. They are examples of **second rank tensors**, which describe material properties and variables that change depending on the direction one points relative to the crystal axes. You will learn more about tensor properties of materials in the second year. For the purposes of this practical it is enough to know one important result from tensor analysis, that when measuring the strain at an angle θ the result obtained is:

$$\epsilon_{\theta} = \epsilon_x \cos^2\theta + \epsilon_y \sin^2\theta + 2\epsilon_{xy} \sin\theta \cos\theta$$

This equation can be used to derive θ from the readings of the three gauges, which give ϵ_{θ} , ϵ_x and ϵ_y . Until you apply torsion to the beam, assume that the *shear strain* $\epsilon_{xy} = 0$.

3. Torsional loading

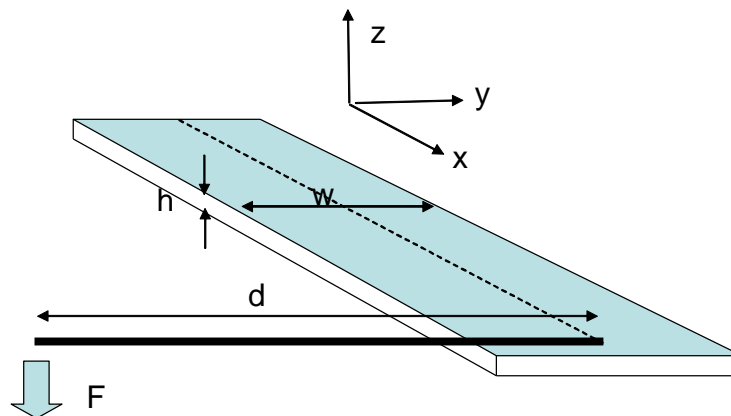

The shear stress τ at the beam surface along the dotted line is given by

$$\tau = \frac{3Fd}{wh^2}$$

